

CS 261: Data Structures

Week 6–7: Binary search

Lecture 7: Augmented search trees

David Eppstein

University of California, Irvine

Spring Quarter, 2026



This work is licensed under a Creative Commons Attribution 4.0 International License

Ranking and unranking

In sorted arrays

$\text{Rank}(x)$ = the position of x in the array
(or the position it would go if added to the array)

Can be found by binary search

$\text{Unrank}(i)$ = the element at position i in the array

Trivial to compute as $\text{Array}[i]$

For example, $\text{Unrank}(n/2)$ is the median

They are inverse operations:

- ▶ $\text{Rank}(\text{Unrank}(i)) = i$, if i is in the range of array indexes
- ▶ $\text{Unrank}(\text{Rank}(x)) = x$, if x is one of the values stored in the array

In dynamic binary search trees

Rank and Unrank are well defined as the position of a given value in the sorted order, and the value at a given position

But it's not obvious how to compute them quickly!

It doesn't work to translate array search directly to trees

- ▶ In array binary search for $\text{Rank}(x)$, we know the rank of each array cell
- ▶ In binary search trees, we cannot store a rank in each tree node, because each update would cause all later ranks to change, too many for fast updating
- ▶ There is no way to translate the trivial array Unrank algorithm into a tree algorithm

Augmented binary search trees

Store **relative rank** in each node: its position among it and its descendants = number of left descendants

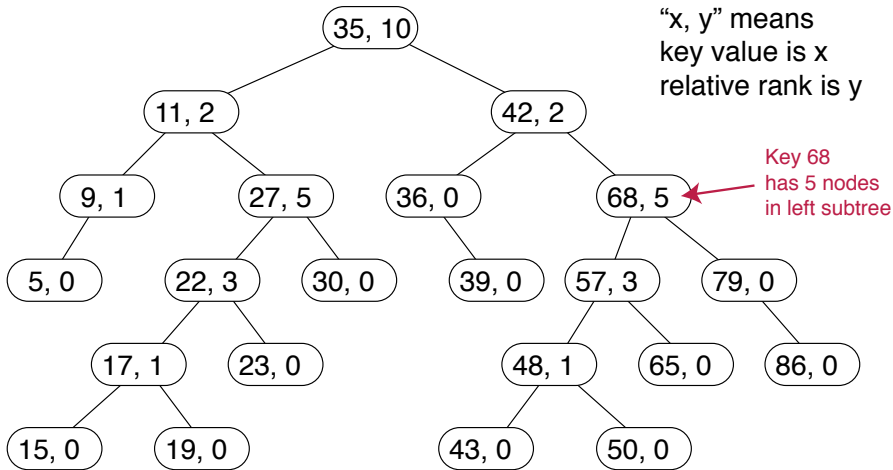

Maintaining relative rank

On insertion or deletion: add or subtract one to all right ancestors

On rotation:

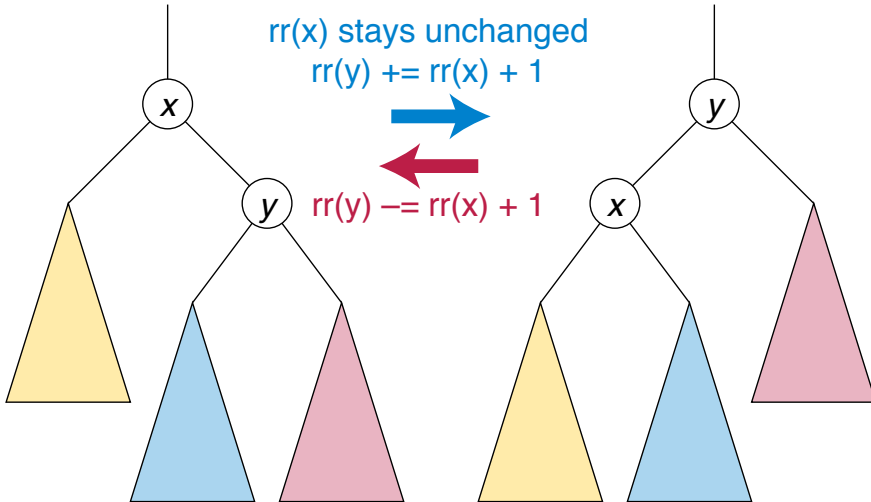

Ranking using relative ranks

Call the following recursive search with `node = tree root`:

```
def rank(x,node):
    if node == None:
        return 0
    else if x <= node.key:
        return rank(x,node.left)
    else:
        return rank(x,node.right) + node.relrank + 1
```

(In splay trees, add splay from last internal node on search path)

Unranking using relative ranks

Call the following recursive search with `node = tree root`:

```
def unrank(i,node):  
    if i == node.relrnk:  
        return node.value  
    else if i < node.relrnk:  
        return unrank(i,node.left)  
    else:  
        return unrank(i - node.relrnk - 1, node.right)
```

(In splay trees, add splay from last internal node on search path)

Ranking and unranking summary

By adding extra information (relative rank) to each node of a binary search tree, we can still update the tree in $O(\log n)$ time, and answer rank and unrank queries in the same time

Works with any rotation-based balanced binary search tree

Related recent research: Ranking and unranking dynamic sorted sets of n integers in the range $[0, n^c]$ can be done slightly faster: $O(\log n / \log \log n)$ per update or query

Pătraşcu and Thorup, “Dynamic Integer Sets with Optimal Rank, Select, and Predecessor Search”, FOCS 2014, <https://arxiv.org/abs/1408.3045>

Range searching

Range searching

Find aggregate information about data elements within a query range [low,high] of values
(or within higher-dimensional regions)

- ▶ Range counting: Number of elements in range
Compute ranks of left and right range endpoints and subtract
- ▶ Range reporting: List all elements in range
- ▶ Range minimum: Find minimum priority value in range
(not minimum value – trivial as successor of left endpoint)
- ▶ Other more complex queries e.g. do a recursive range search on another attribute for elements within range

Range reporting

Call with node = tree root:

```
def report(low,high,node):  
    if low < node.value:  
        report(low,high,node.left)  
    if low <= node.value <= high:  
        output node.value  
    if node.value < high:  
        report(low,high,node.right)
```

Analysis of range reporting

Whenever we recurse into both children, we also output the node value

Every recursive call is one of:

- ▶ A node whose value is output
- ▶ A node on the search path for the low range endpoint (at which we search only the right child)
- ▶ A node on the search path for the high range endpoint (at which we search only the left child)

Time = $O(\text{number of nodes searched}) = O(\text{output size} + \log n)$

An algorithm whose time depends on output size and not just on input size is called “output sensitive”.

Decomposable range search problems

Suppose:

- ▶ We have a collection of key,value pairs with sorted keys
- ▶ An associative binary operation \oplus operates on the values
- ▶ We want to find the result of applying \oplus to the values whose keys are within a query range [low,high]

If we can decompose a range into disjoint sets, $S \cup T$, we can use \oplus to combine results for each set: $\text{total} = \text{result}(S) \oplus \text{result}(T)$

Examples:

- ▶ Range counting, value = 1, \oplus = addition
- ▶ Range reporting, value(x) = $\{x\}$, \oplus = set union
- ▶ Range minimum, value = priority, \oplus = minimization

Partition of range into subtrees

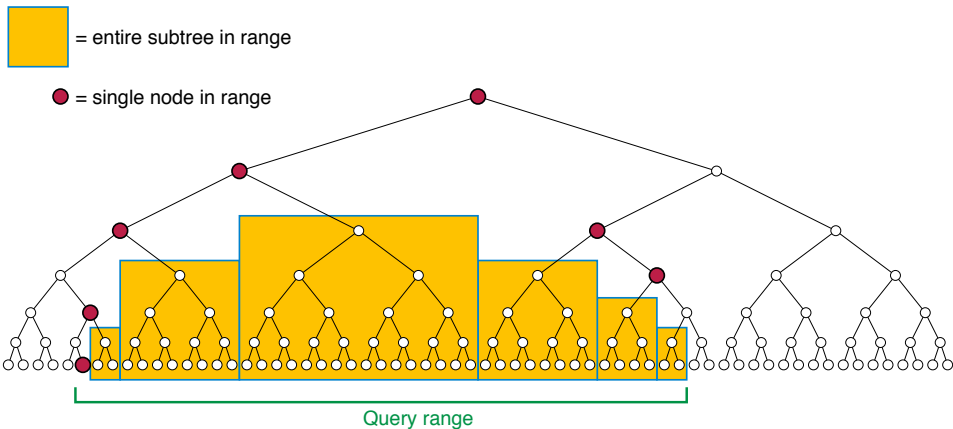

Idea: search paths for range endpoints have length $O(\log n)$

We can decompose the range into $O(\log n)$ nodes on these two paths and $O(\log n)$ entire subtrees between them

Store \oplus for each subtree, combine stored results for query total

Decomposable query algorithm

As we recurse, replace range endpoints by flag values $-\infty$ and $+\infty$ in subtrees for which endpoints are no longer relevant

Whole tree is in range when both endpoints are infinite

To query range $[low, high]$ at a given node:

- ▶ If $low = -\infty$ and $high = +\infty$, return stored value for subtree
- ▶ If $key > high$, return $query(low, high, left\ child)$
- ▶ If $key < low$, return $query(low, high, right\ child)$
- ▶ Return $query(low, +\infty, left\ child) \oplus$
node's value $\oplus query(-\infty, high, right\ child)$

Time: $O(\log n)$ for operations with \oplus time $O(1)$

Maintaining the stored subtree values

Whenever a node's stored subtree value might have changed

- ▶ We added or removed a descendant
- ▶ It was involved in a rotation

Recompute its subtree value as

left subtree value \oplus right subtree value \oplus node's value

Time per insertion or deletion $O(\log n)$

(under same assumptions on \oplus time as for query)

Works for any balanced binary search tree

Multi-level range search

Example: Rectangular range counting

Data: 2d points represented as (x, y) coordinate pairs

Query: How many points are inside a given rectangle?

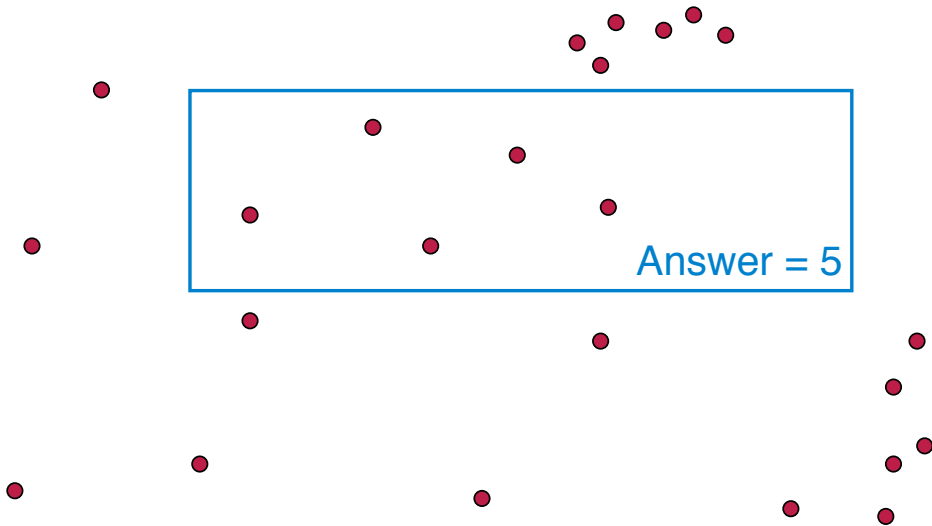

Binary search tree on x -coordinates

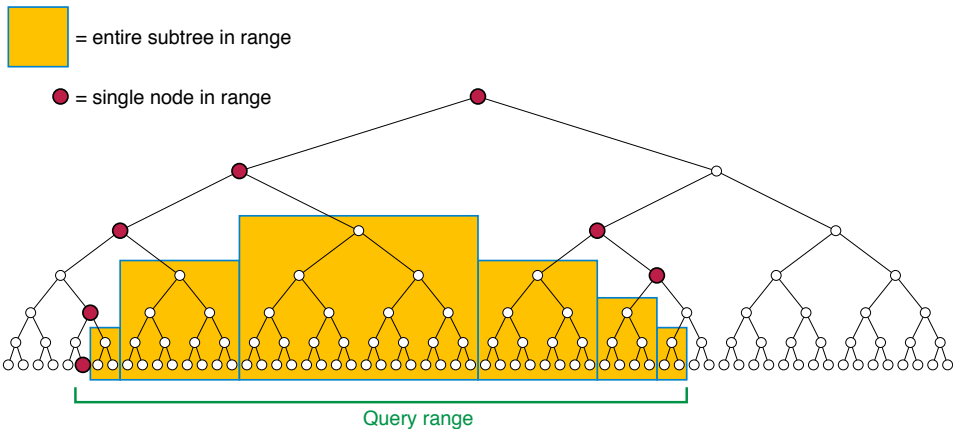

Query range: left and right x -coordinates of rectangle

Decomposes the points whose x -coordinate is in range into

- ▶ $O(\log n)$ individual points
- ▶ $O(\log n)$ larger sets of points

Multi-level structure

Binary search tree of points sorted by x -coordinates

Each node stores a 1D range search structure for intervals of y -coordinates, for points in its subtree (e.g. a sorted array)

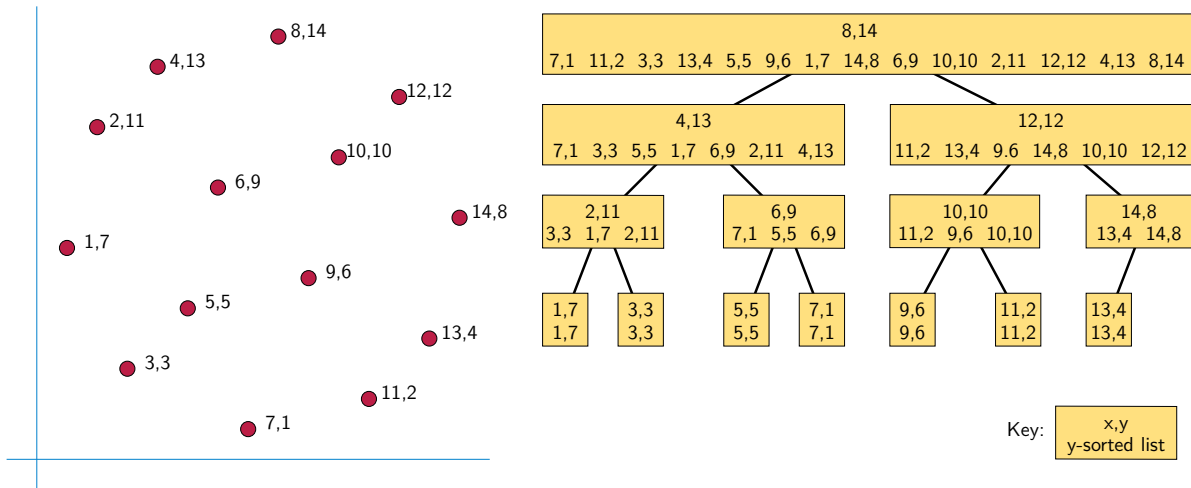

Using a multi-level structure

To count points in a query rectangle:

- ▶ Perform query on x -range of rectangle
- ▶ For each individual point (x, y) found by query:
 - Test whether y is in range
- ▶ For each subtree identified by query:
 - Use 1d structure at subtree root to count descendants whose y coordinate is in range
- ▶ Add the results and return the total

If x -tree is balanced \Rightarrow each point contributes to $O(\log n)$ y -structures \Rightarrow space $O(n \log n)$

Each rectangle query makes $O(\log n)$ calls to y -structures \Rightarrow query time $O(\log^2 n)$

Related binary searches \Rightarrow speed up queries to $O(\log n)$ using **fractional cascading** (not covered)

Making it dynamic

Suppose we want to insert or delete points?

- ▶ Use a dynamic binary search tree on x -coordinates
- ▶ Replace 1D sorted arrays by dynamic binary search trees on y -coordinates

We cannot rotate quickly because that would cause big changes to the 1D structures

Instead, use a subtree-rebuilding based balanced binary search tree on x -coordinates

(treap, $BB[\alpha]$ -tree, or scapegoat tree)

When we rebuild a subtree we also rebuild the recursive structures stored in its nodes

Lower bounds

Lower bounds on data structures

We have seen:

- ▶ Optimality of binary heap for comparison-model priority queues
Based on the ability to sort using heaps
Can be sidestepped by using integer arithmetic and array indexing instead of only comparisons (e.g. flat trees)
- ▶ Impossibility of nontrivial set disjointness
Based on unproven assumption (SETH)

This time: Lower bounds for range search

Proven rigorously in a very general computational model

Are augmented search trees optimal?

We have seen that a very general class of dynamic range searching problems can be solved in time $O(\log n)$

Natural question: Is that the right time bound or can we do better?

Answer: we can prove $\Omega(\log n)$, for:

- ▶ Simple and natural range searching problem: **range sum**
Data = ordered keys and numeric values
Query = sum of values for key-value pairs with key in range
- ▶ A very general model of computing: **cell probe model**
Only measure communication between CPU and memory

Warmup interview question: Static range sums

You are given an array of n numbers

Problem: process it so you can quickly find the range sum

$$A[i] + A[i + 1] + \dots + A[j - 1] + A[j]$$

Solution

Store an array of prefix sums

$$PS[i] = \sum_{j=0}^i A[j] = A[0] + A[1] + \dots + A[j] = PS[i - 1] + A[i]$$

Return $PS[j] - PS[i - 1]$

Linear space and preprocessing, constant time per query

Prefix sum problem

Simplified version of the range sum problem

(for lower bounds, simpler problem \Rightarrow stronger bound)

Maintain array $A[0] \dots A[n - 1]$ of numbers

Update(i, x): set $A[i]$ to new value x

Query(i): calculate prefix sum $A[0] + A[1] + \dots + A[i]$

(If these operations are hard, so are the more general operations of insertion + deletion + range sum)

Log-time solution

Build a perfectly balanced binary tree with array A at its leaves

Each internal node stores sums of its two children

Query(i): sum up left children on search path to $A[i]$

Update: recompute node sums on path to root

Claim: No other data structure can achieve better O -notation

We need to define what an “other data structure” might be

Cell probe model of computing

Central processor has $O(1)$ registers, each holding one word (binary value of length $w \geq \log_2 n$);
memory has up to 2^w words

We count only steps that move a word between CPU and memory \Rightarrow lower bound doesn't depend
on what other steps are allowed

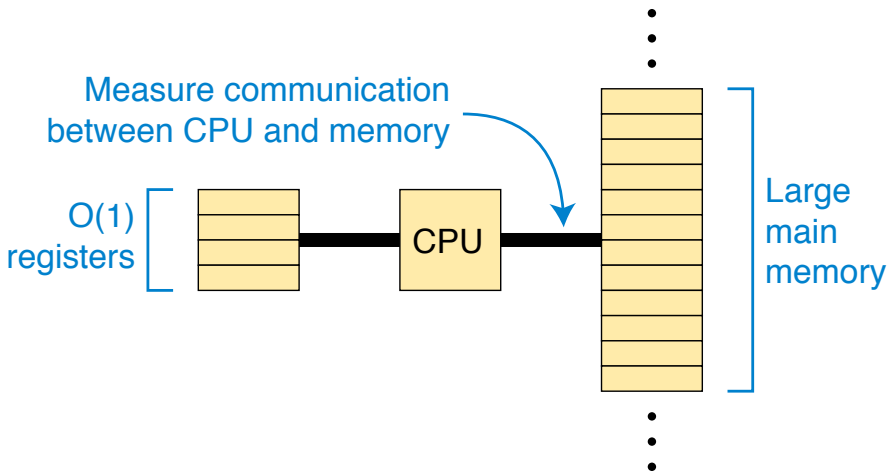

Fitting prefix sums to cell probe model

We are going to prove a lower bound for
prefix sums of n w -bit binary numbers

(representation size of the input values should be
the same as the word size of the computer)

We will use $n =$ a power of two (unrelated to word size)

To avoid questions of integer overflow,
we will assume all arithmetic is modulo 2^w

(just do binary addition and ignore overflows)

Goal: Find a sequence of prefix sum operations that forces any correct data structure to do a lot
of CPU–memory communication

A special permutation of n

Assume $n = 2^k$

Define “bit reversal permutation” $r(i)$:

- ▶ Write i as a k -bit binary number
- ▶ Reverse the bits
- ▶ Interpret the result as a binary number

E.g. for $k = 8$, $222_{10} = 11011110_2$
becomes $01111011_2 = 123_{10}$

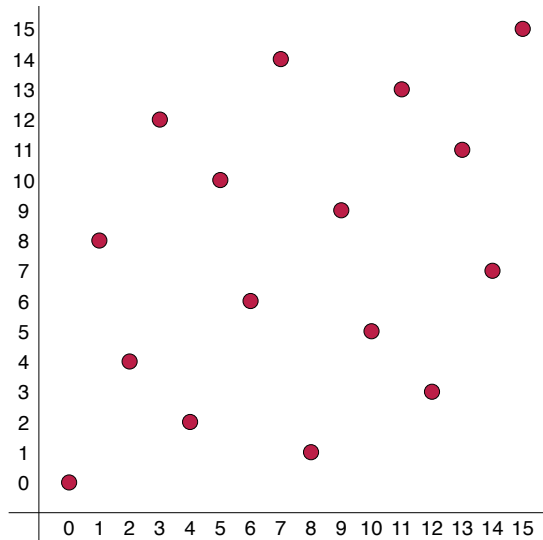

Computing sequence of bit-reversals

To compute a sequence of length 2^k , consisting of all k -bit numbers in bit-reversed order, compute the same sequence recursively for $k - 1$ and use it twice:

```
def bitrev(k):  
    if k == 0:  
        return [0]  
    L = bitrev(k-1)  
    return [2*x for x in L] + [2*x+1 for x in L]
```

$[0] \rightarrow [0, 1] \rightarrow [0, 2, 1, 3] \rightarrow [0, 4, 2, 6, 1, 5, 3, 7] \rightarrow \dots$

Each value in the second half of the sequence is one plus the corresponding value in the first half

A difficult sequence of prefix-sum operations

Initialize all data values $A[i]$ to zero, then:

For each index i in $\text{bitrev}[k]$:

- ▶ Set $A[i]$ to be a random w -bit number
- ▶ Query the prefix sum $A[0] + \dots + A[i]$

E.g. when $n = 8$, $k = 3$, we perform the operations

Update(0,random), Query(0), Update(4,random), Query(4),
Update(2, random), Query(2), Update(6,random), Query(6),
Update(1,random), Query(1), Update(5,random), Query(5),
Update(3,random), Query(3), Update(7,random), Query(7)

A binary tree on the sequence of operations

This is not a data structure! It's just a mathematical tree that we will use in the lower bound proof.

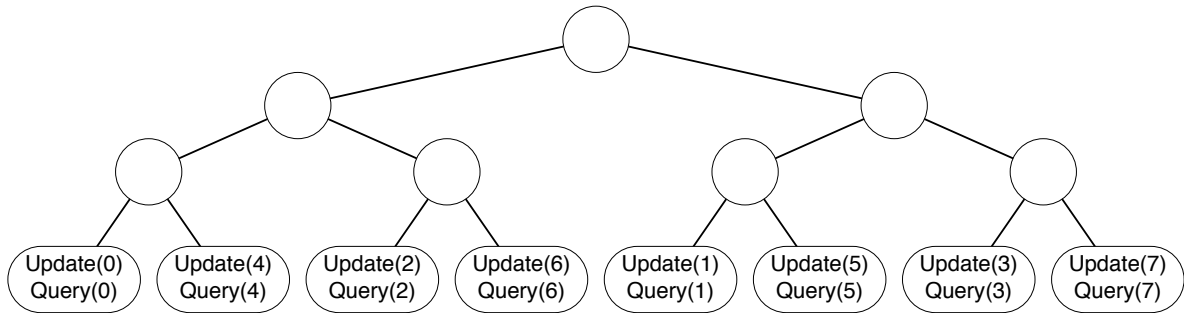

Information transfer

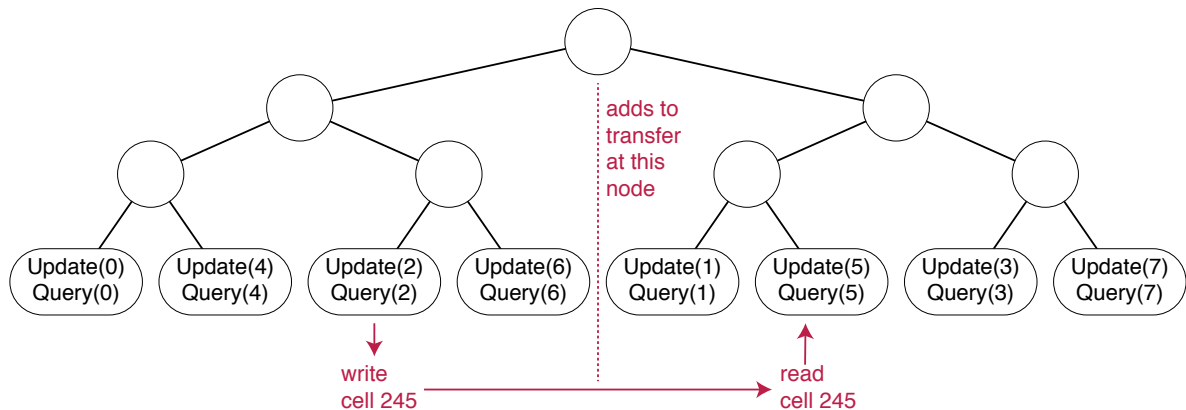

For any data structure for prefix sums, and any node x of this tree, define the **information transfer** of x to be the number of times an operation in the right descendants of x reads a memory cell that was last written during the operations in the left descendants of x

Each memory read contributes to information transfer at ≤ 1 node \Rightarrow total number of read steps \geq total information transfer

Information transfer \geq descendants/2

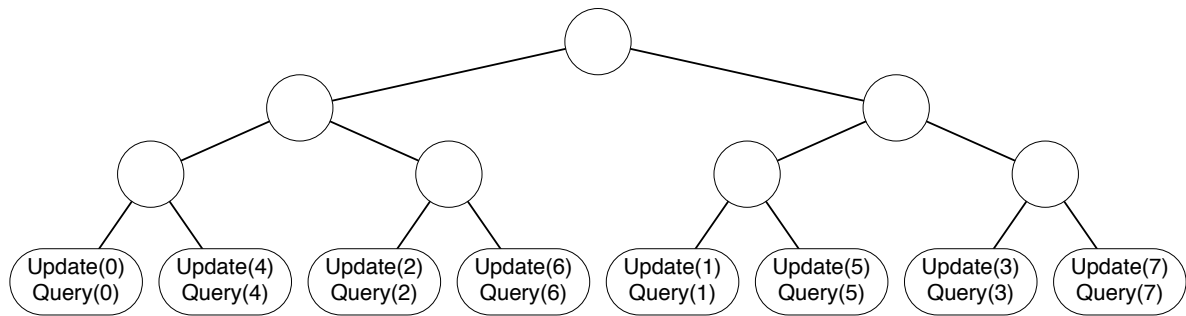

Information transfer = number of times an operation in node's right descendants reads a memory cell last written on the left

Let $d = \# \text{descendants} / 2 = \# \text{left updates} = \# \text{right queries}$

There are 2^{wd} different possible values for the updates on the left, each of which would produce different query results on the right

(Independently from information derived from non-transfer reads)

Finishing the lower bound

Information transfer at root node of tree: $\geq n/2$

Information transfer at i th level of tree:

2^i nodes with transfer $\geq n/2^{i+1}$, total $\geq n/2$

Total over whole tree: $\geq (n/2) \times \# \text{ levels} = (n/2) \log_2 n$

There are $2n$ prefix sum operations (updates and queries together) \Rightarrow average number of memory reads per operation $\geq \frac{1}{4} \log_2 n$

Every prefix sum data structure that fits into the cell probe model of computation requires $\Omega(\log n)$ time per operation

\Rightarrow same is true for dynamic range sum data structures

Summary

Summary

- ▶ Ranking and unranking operations; efficient dynamic implementation by augmenting search tree with relative ranks
- ▶ Types of range searching problems including range counting, range reporting, range minimum, and range sum; decomposable problems using associative binary operation
- ▶ Dynamic range searching by augmenting search tree with value of its subtree and decomposing range into a logarithmic number of subtrees and individual nodes
- ▶ Cell probe model of computing and lower bound on dynamic prefix sums
- ▶ Multi-level range search and multi-level augmented binary search trees